

Always be your solar support

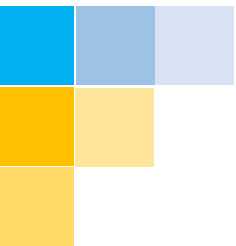

Installation Manual—Rail IV Pitched Roof Solution

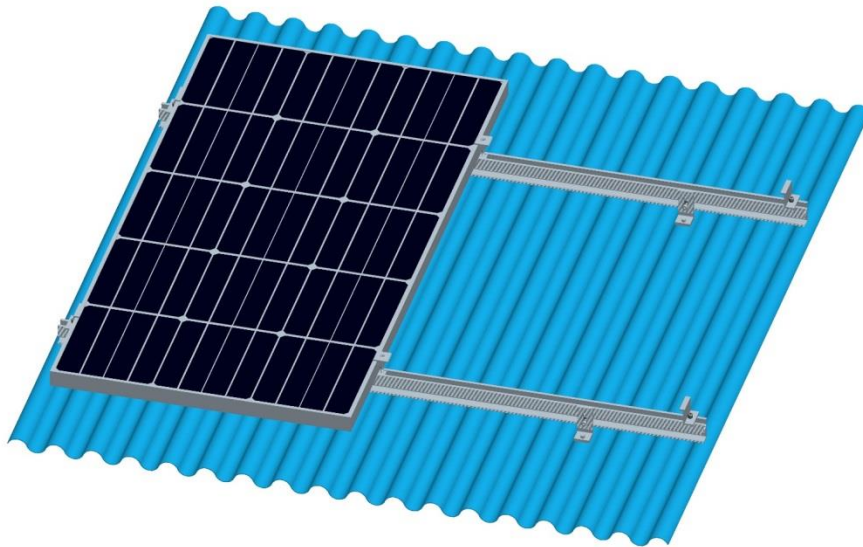

Version 2016 1.0

www.antisolar.com

GENERAL INTRODUCTION

Antaisolar Roof Mounted solutions, accommodating a wide range of modules, are suitable for most types of roofs. With innovative Antaisolar Rail and T module, Antaisolar Roof Mount enables significantly faster, easier installations, which have been developed into one of the most versatile mounting solutions in the world, delivering time and cost effective experience to solar system installers.

Rail IV

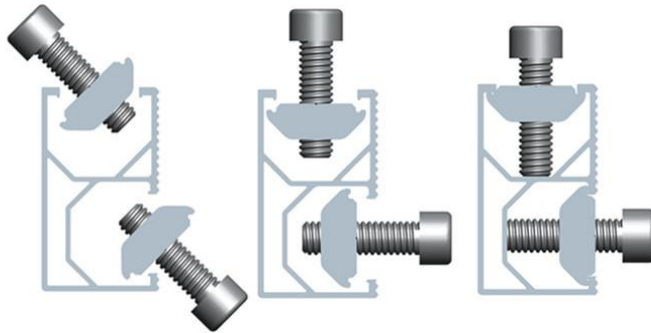

Easy to be installed

Antaisolar features series of highly engineered new innovative product, designed with experienced engineers to the speed of installation. Antaisolar pitched roof solar mounting system is backed by a 10-year warranty and is compliant with AS/NZS1170.2.2011 Amdt 3 – 2012

Benefits of Antaisolar Pitched Roof Mounting System



- Easy Installation
- Diversified Application
- High Accuracy
- Choice Quality
- Engineered to highest standards
- Maximum Lifespan
- Guaranteed durability

TECHNICAL SPECIFICATIONS



Applications

- Commercial and residential buildings
- Marine applications and remote areas

Features

- Anodized 6005-T5 aluminum extrusion
- Innovated designed of the Tilt-in modules, which can be pre-assembly with the clamp, make the installation easy and quick.
- Suitable for difference conditions and the most solar panels at present market.
- Significantly higher strength-to-weight ratio than other framing products, providing improved efficiency due to greater frame spans, inherent corrosion resistance resulting in low ongoing maintenance and an extended product life.
- Complies with Australian/New Zealand Standard on Wind Actions, AS/NZS1170.2.2011 Amdt 3 – 2012
- 10 years limited warranty backed up by parent company Antai Aluminium

Material

Material	Tensile strength	
	Ultimate	Yield
6005 T5 aluminum extruded	260Mpa	240Mpa
Stainless steel 304	625.55Mpa	263.8Mpa
Stainless steel A2-70	700MPa	450Mpa

Installation condition

Roof slope	Up to 60°
Building height	Up to 20m
Mounting structure	Timber/ steel
Roof types	Tile/Tin/Klip-Lok® roof
System angle	Flush with roof

Note: If the condition is beyond the table list, please contact us to confirm



SAFETY AND INSTALLER RESPONSIBILITIES

Handling and Installing Antaisolar

It is critically important that safety practices are observed when installing

- Do not throw or roughly handle any Antaisolar components.
- Do not bring Antaisolar system into contact with sharp or heavy objects.
- Do not modify Antaisolar components in any way. The exchange of bolts, drilling of holes, bending or any other physical changes not described in standard installation procedure will void the warranty.
- It is the installer's responsibility to verify the integrity of the structure to which Antaisolar components is fixed. Roofs or structures with rotten/rusted bearers, undersized bearers, excessively spaced bearers, or any other unsuitable substructure cannot be used with Antaisolar components, and installation on such structures will void the warranty, and could result in death or serious injury.

Wind and Climate Design

AS/NZS1170.2.2011 provides guidance on determining the wind pressures applicable to your Antaisolar system install site, taking into account roof shape and geographic location. Sufficient guidance is given in this document, but you may wish to procure a copy of these standards if your company installs Australia/New Zealand wide.







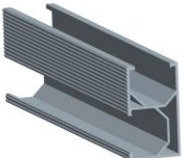
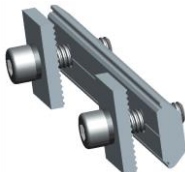

- REMEMBER average wind speeds are higher for structures mounted closer to the roof perimeter zone (edge). Refer to 'Fixing within Roof Installation Zone' for more information)
- Make sure your installation complies with local and national building codes. Take into account relevant design parameters (wind speed, exposure and topographic factor) when determining the loading for the installation.
- If alternative fasteners are used to fix the framing to the roof (assuming supplied fasteners are unsuitable for any reason), all screw fasteners must conform to corrosion resistance Class 4 Australian Standard AS3566 and be of equal or greater strength to those supplied with your Antaisolar system order.

CAUTION: INSTALLATION OF THIS PRODUCT IS TO BE PERFORMED ONLY BY PROFESSIONALLY TRAINED INSTALLERS. ANY ATTEMPT BY AN UNQUALIFIED PERSON TO INSTALL THIS PRODUCT COULD RESULT IN DEATH OR SERIOUS INJURY.



COMPONENTS LIST

Overview of system components

Part name	Picture	Part name	Picture
Rail IV		Rail splice for rail IV	
T-module		L Bracket (L Foot)	
Inter Clamp (with T-module)		End Clamp (with T-module)	
Tile Roof hook		Hexagon socket bolt M8*30/45/50/55/60	
Klamp Lock 700		Klamp Lock 406	

Note: The quantity of requested components depends on the system you ordered.









BEFORE INSTALLING

Receipt of goods

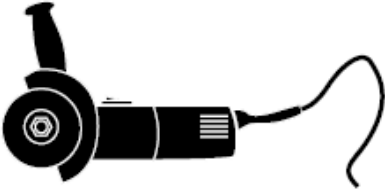
Check that the Antaisolar equipment is undamaged and that the order is complete. Check for correct quantities of the items.

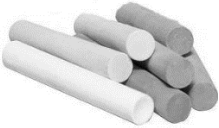
Tools required for installation

<p>6 mm Allen key or hexagonal driver bit. If using a 6mm driver bit, make sure the cordless power tool used for the driving has a hand-tight clutch setting a fine (soft) impact drive to prevent damage to the fragile glass panels and threads on the structure.</p>	
<p>Cordless drill. Drill or impact driver for driving roof material fixings</p>	
<p>Angle grinder. For terracotta tile roof installation, and angle grinder fitted with a continuous edge diamond tipped tile cutting blade; gloves, hearing protection, a face protection mask, and a suitably rated breathing protection mask for all people in proximity of grinding</p>	
<p>Gloves. Protect the hazard of the sharp corners.</p>	
<p>Cord or color pen. Mark the installation position.</p>	
<p>Spirit level</p>	
<p>Measuring tape</p>	



* If necessary, timber to shim the roof hook

INSTALLATION PLANNING

DETERMINING WIND TERRAIN CATEGORY

Terrain Category 2

Open terrain, including grassland with well scattered obstructions having heights generally from 1.5 meters to 5 meters. Examples include farmland or cleared sub-divisions with isolated trees and uncut grass.

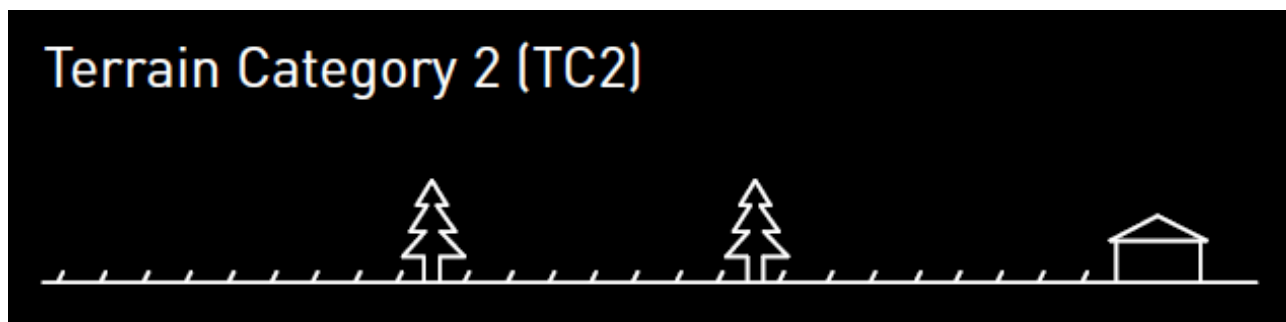

Terrain Category 3

Terrain with numerous closely spaced obstructions having heights generally from 3 meters to 10 meters. Examples include typical suburban housing or light industrial areas.

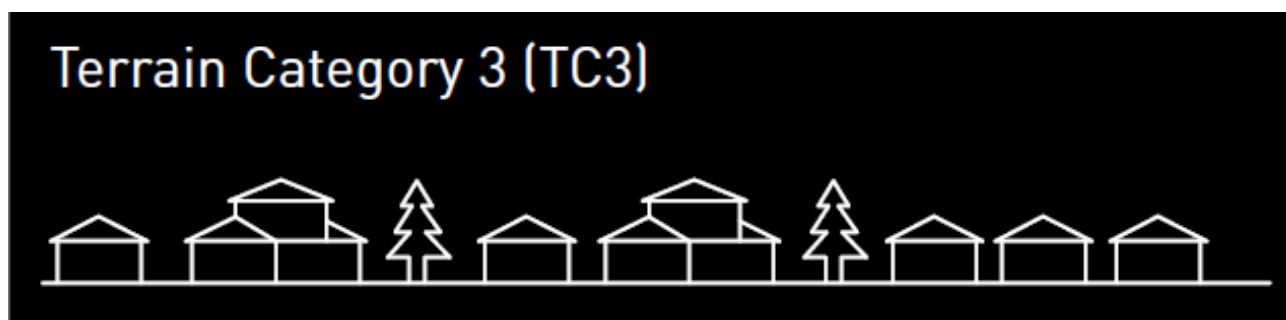

DETERMINING WIND REGION

Figure: National wind map (in accordance with AS/NZS 1170.2:2011/Amdt 3:2012)

Wind regions are pre-defined by Standard AS/NZS 1170. The Wind Region has nothing to do with surrounding topography or buildings.

Wind Zone	A	B	C	D
Wind Speed (m/s)	41	48	69	88

PLANNING THE MODULE AREA

Solar panels can be installed anywhere on the roof, as long as sufficient fixings are used. Higher wind speeds are encountered at the edges of roofs and therefore more fixings are required in these areas. For a flush mounted array, a roof can be divided into two zones, the central zone and the end zone. The width of these zones can be determined based on the length of the building.

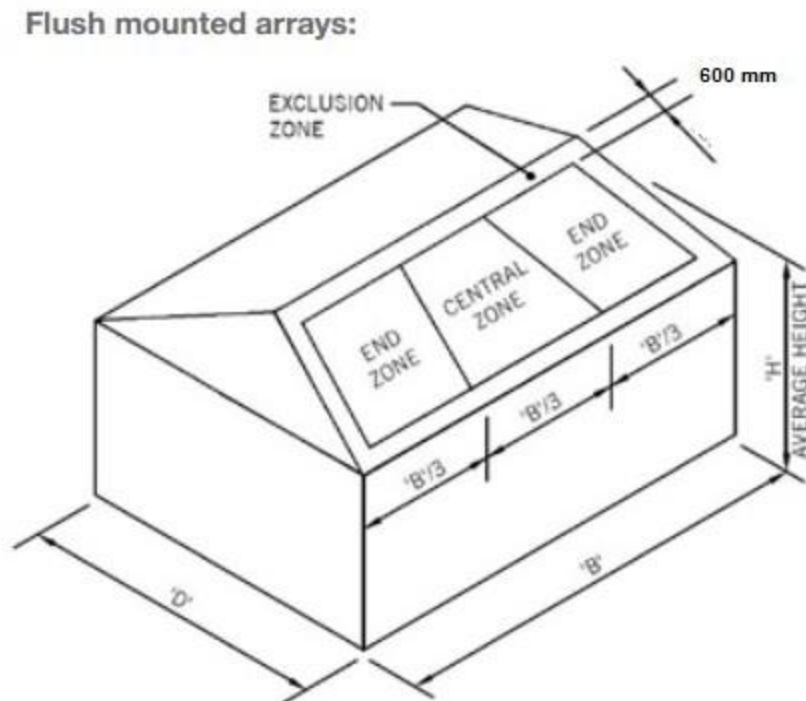

Determining the width of the central and end zones, ' $B/3$ '. The width of the central and end zones is determined by calculating the roof length and dividing this result by 3. An exclusion zone of 600 mm must be made on the edges of the roof.



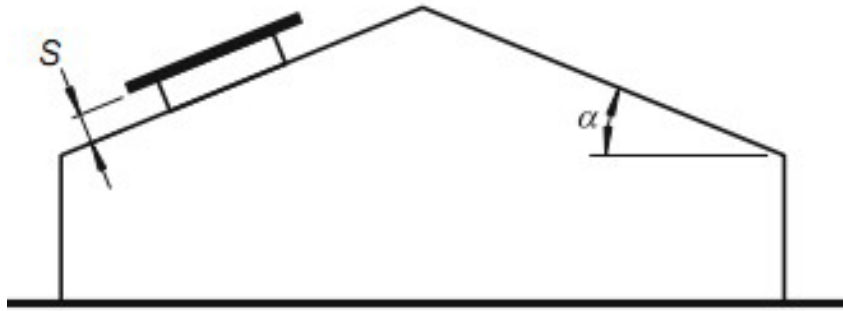

Figure: Panel must be installed flat to the roof

DETERMINE THE HEIGHT OF THE INSTALLATION SITE

This document provides sufficient information for Antaisolar system installation height less than 20 meters. If your installation site is more than 20 meters in height, please contact Antaisolar to obtain engineering data to support your installation.

VERIFY ACCEPTABLE RAIL END OVERHANG

Rail end overhang must equal 50 percent or less of foot spacing. Thus, if foot spacing is 1200mm, the Rail end overhang can be up to 600mm. In this case, two feet can support a rail of as much as 2400mm (1200mm between the feet and 600mm of overhang at each end).

DETERMINE ROOF SLOPE

Antaisolar mounting system can be used for roof slope up to 60 degrees. This document provides sufficient information for below 30 degrees, please contact Antaisolar for between 30 and 60 degrees.

DETERMINE THE MAXIMUM RAIL SUPPORT SPACING

Please use the table in certification of compliance to determine the Antaisolar Rail IV support spacing for installations. Certification of compliance please request from dealer or contact Antaisolar. Below only for reference.



Client: **Xiamen Antai New Energy Tech. Co., Ltd.**
 Project: **Solar Array Interface Spacing Table**
 Address: **Within Australia**
 Designed: **B.C**

Job: **1850**
 Date: **Sep-15**

Solar Array Interface spacing Table for Tin Roof

Type of Rail Rail IV
 Type of Interface ATL-FWNY-05
 Solar Panel Dimension 2mx1m
 Terrain category 3
 Roof Angle (Φ) – $\Phi < 5^\circ$

Wind Region	Building Height - H (m)							
	H≤10		10<H≤15		15<H≤20			
	D.W & U.W	Central	D.W & U.W	Central	D.W & U.W	Central		
A	1375	1493	1297	1407	1240	1344		
B	1196	1407	1031	1268	918	1128		
C	332	406	287	351	257	314		
D	208	254	181	220	162	197		

Roof Angle (Φ) – $5^\circ \leq \Phi \leq 30$

Wind Region	Building Height - H (m)							
	H≤10		10<H≤15		15<H≤20			
	D.W & U.W	Central	D.W & U.W	Central	D.W & U.W	Central		
A	1375	1596	1297	1502	1240	1434		
B	1196	1503	1031	1416	918	1331		
C	332	477	287	412	257	368		
D	208	297	181	258	162	230		

Note: The above spaces are based on 1.5mm purlin only

INSTALLATION INSTRUCTION

● Installation of L-bracket on Metal Roof

1. Determine the positions of the L-bracket according to your plans.

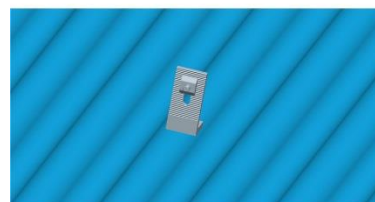

2. Fix the L bracket (together with Rubber Pad) to the rafter using SUS 410 Screw, fix other L brackets to the rafter according to your plans.
 Note: The rubber pad plays the role of waterproof.

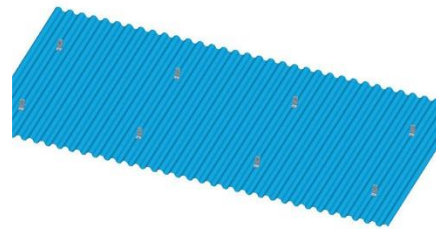

● Installation of Klamp Lock on Metal Roof

3. Use our Klamp Lock to clip the metal roof tightly, and place L-Bracket on Klamp Lock and connect them by tightening M8*20 Bolt.

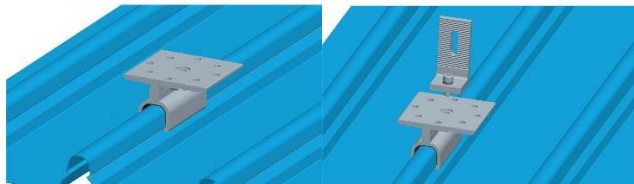

Note: If Klamp Locks are being used then fixing centres are subject to those outlined installation manual for Klamp Lock 406 & Klamp Lock 700.

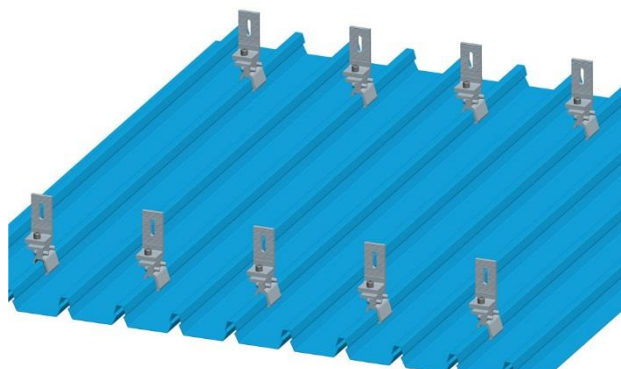

4. Connect the L bracket with rail IV by T-module and tighten the bolt.



5. If you need, to connect multiple rails together, slide the splices on the rear side of the pre-assembled rails halfway to the side. Fasten the first M8 bolt firmly using the Allen key. Now slide the next rail segment into the splice. Tighten the second M8 bolt .The connection is finished.

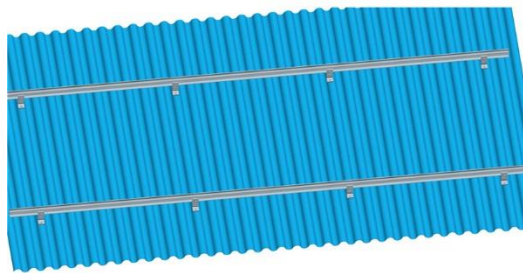

● Installation of Tile Hook on Tile Roof

6. Remove the roof tiles at the marked positions or simply lift them up slightly then input the roof hook to the wooden beam. Fix the roof hooks with 3x self-tapping screws. Minimum 2 pcs

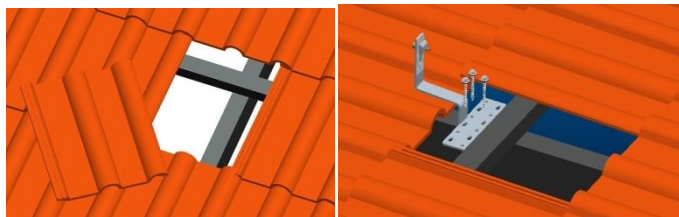

7. Cover the hooks by the removed tile



8. Connect the roof hook with the rail.
 a. Insert the tilt-in module into the side channel of the rail as the step 9 shown.
 b. Adjust the rail to be level.
 c. Fasten the bolt.

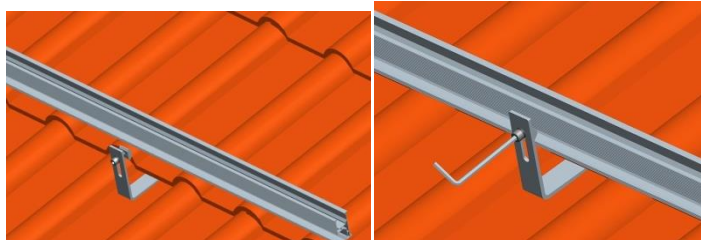

Note: If necessary, use an angle grinder or hammer to cut a concavity in the tile that covers the roof hook at the point where the roof hook comes through. (Caution! Must not use fixed roof hook as a ladder, as this extreme point load could damage the tile below.)

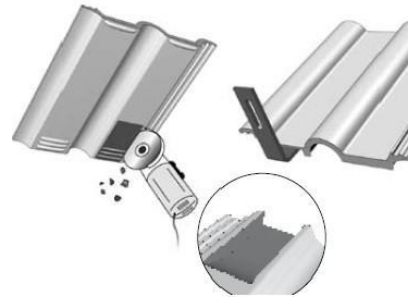

9. Place the solar module on the rails, slide the end clamp tightly against the solar module and fasten tightly using the Allen bolt (recommended torque is 8 Nm)

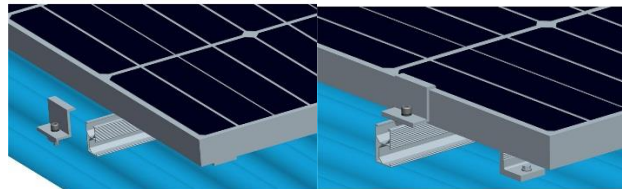
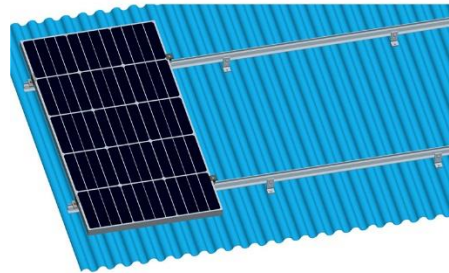

10. Slide the pre-assembled inter-module clamp into the rails from above, place it firmly against the module and fasten loosely (approx. 2-3 turns).

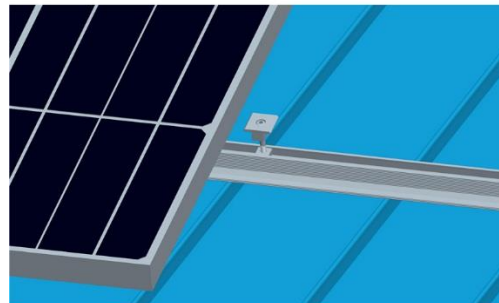

11. Now slide the next module against the previously installed module and tighten the inter-module clamp using the Allen key, Take care that the anti-slips protection sits in the rail channel of the lowest row of rails.

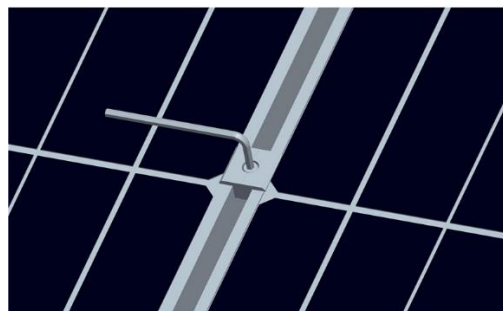

12. Place the last module in the row on the rails (with the first row of modules, take care that the anti-slip protection sits properly in the rail channel) and fasten the last inter module clamp and the module end clamp using the Allen Key (recommended torque is 8 Nm).

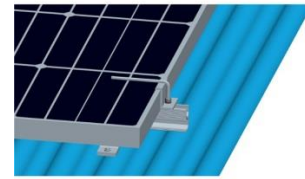

13. For each use of the T module. You must make sure that: the thread of the screws does not project through the lower side of the T module (max flush). Position the T module in the rail channel and fasten it loosely with 2 to 3 turns of the screw. The screws can still be freely moved in the rail channel. Slide the screw to their final position in connection with the inter-module clamp, module end clamp or roof hooks/hanger bolts and fastens firmly.

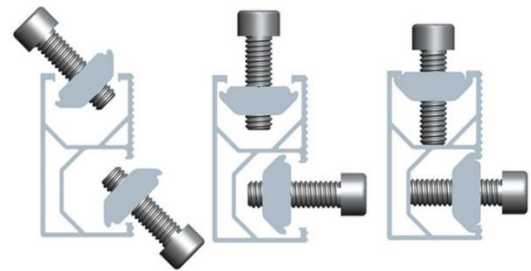

14. Now first row of modules are installed, continue to mounting next row of modules according to steps 7 to 10.

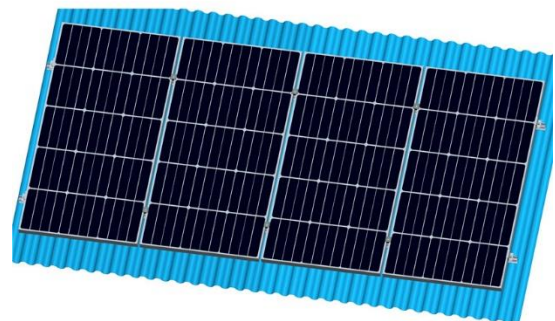

15. Antai rail grounding system

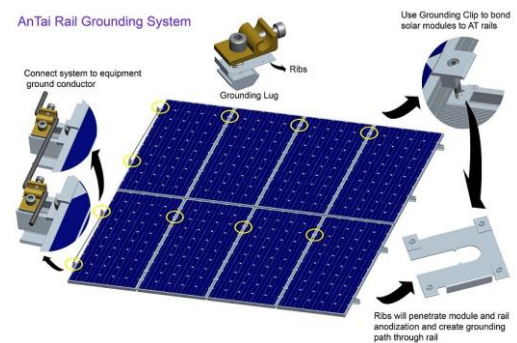

WARRANTY

In so far as Xiamen Antai New Energy Tech. Co., Ltd. (Hereafter called Antaisolar) grants the customer a 10 year warranty to solar mounting systems, except for the anodized finish, which finish shall be free from visible peeling, or cracking or chalking under normal atmospheric conditions for a period of five (5) years. The Warranty Start Date is the date of delivery of the Product(s) to the Buyer or 2 months after the date of Product(s) dispatch from Antaisolar manufacturing site, whichever date is earlier.

Warranted Products

All anodized aluminum products and stainless steel 304 components in the solar mounting systems.

Exclusions and Limitations

In the event that damage is caused to a purchased item, despite proper installation and handling and in the context of normal use and maintenance, Antaisolar will immediately exchange the respective component within the warranty period. The following terms shall apply

1. Failure to comply with Antaisolar's installation manual;
2. Service by service technicians who are not qualified under the relevant law and/or applicable regulations at the place of installation;
3. The warranty period for each component defined in the respective product sheet by Antaisolar shall apply. The warranty period commences with the transfer of risk of the respective component; if, for particular components, generally or for a particular type of use a possible shorter life is expressly indicated within Antaisolar's individually-generated plans, an exchange is scheduled within a shorter period, the warranty period shall be restricted to such life or period.
4. The warranty is limited to additional delivery for the defective components upon notification of the damage within the warranty period. Any statutory guarantee or liability claims shall remain unaffected.
5. The obligation to fulfill the warranty shall not apply if the damage has arisen in connection with exceptional stress (e.g. storm damage, impact of instability of the sub-surface, particular chemical or biological effects). Or in such conditions, accident, force of nature (such as lightning strike, earthquake), influence from chemical products or other acts beyond Antaisolar's reasonable control (including damage by fire, flood, etc.)
6. With regard to installation and handling, the technical product descriptions and installation instructions regarding the respective products as supplied by us shall apply, as shall the statutory and generally-recognized standards and principles of building and construction work in local market as well as, as appropriate, on a priority basis, the plans, statics and instructions prepared by us individually for the customer.
7. No claims shall exist if the damage is covered or can usually be covered by insurance against storm and similar events (natural-peril insurance).
8. This warranty shall only be applied to solar mounting systems designed by Antaisolar. Custom design products if suggestions by Antaisolar are declined, this product is excluded in this warranty.
9. This warranty shall only establish claims of Antaisolar's customer, via which all warranty claims are to be settled. Assertion by third parties shall only be possible if Antaisolar agrees thereto.
10. Limited Warranty does not apply to any Products which have been subjected to use of the Products in such a manner as to infringe Antaisolar's or any third party's intellectual property rights (e.g. patents, trademarks).



Repair, Replacement or Refund Remedy

1. As Buyer's sole and exclusive remedy under this Limited Warranty (though Buyers should note paragraph 4 below regarding the potential existence of other statutory rights), Antaisolar will, in its sole discretion, either, with regard to the applicable Product (or component thereof in the case of Mounting Product):
 - a) refund the historical purchase price of the relevant Product(s); or
 - b) repair the defective Product(s) at no charge (subject to the following paragraph); or
 - c) replace the defective Product(s) or part thereof by a new or remanufactured equivalent at no charge (subject of the following paragraph).

In the event that Antaisolar opts for options b) or c), Antaisolar shall bear all insurance and transportation charges (except air freight, courier freight), customs clearance and any other costs for returning the defective Product(s) to Antaisolar and shipping the repaired or replaced Product(s) to Buyer (a Buyer may claim reimbursement by Antaisolar for these charges by contacting Antaisolar and providing proof to Antaisolar that these charges were incurred, e.g. an invoice from the relevant service provider). The costs and expenses for their removal, installation or reinstallation shall remain with Buyer.

2. The warranty period(s) shall not extend or renew upon the repair or replacement of a defective Product by Antaisolar. The warranty period for replaced or repaired Product(s) is the remainder of the warranty on the original new Product(s).

3. All other claims under this Limited Warranty against Antaisolar shall be excluded. Under this Limited Warranty, Antaisolar is not responsible for any special, incidental or consequential damages (including loss of profits, harm to goodwill or business reputation, or delay damages) whether such claims are based in contract, warranty, negligence or strict tort. This exclusion applies to the extent permissible by law, and even if the remedies set forth below herein are deemed to have failed of their essential purpose.

Rights and Remedies against Third Parties

This Limited Warranty shall be construed as a separate warranty and independent from any other contractual arrangement with third parties relating to the Product(s). It shall not affect any rights, obligations and remedies of the Buyer, if any, with regard to third parties for defects or non-conformity or non-compliance of the Products, notwithstanding its legal basis. The rights and remedies provided hereunder are in addition to any other rights and remedies against third parties to which Buyer may be entitled by agreements with such third parties or by law.

Claims Procedure, Notice Periods, Expiration of Warranty Claims and Limitations

1. Buyer shall notify Antaisolar immediately after discovery of any claim under this Limited Warranty by letter, facsimile or e-mail specifying each alleged claim including evidence of the claims and the serial numbers of the Product(s) at issue.
2. Any claim for breach of this Limited Warranty must be brought within three (1) months after discovery of the breach.
3. The return of any defective Product(s) will not be accepted unless prior written authorization has been given by Antaisolar.



Force Majeure

Antaisolar shall not be responsible or liable in any way to the Buyer for any non-performance or delay in performance under this Limited Warranty due to occurrences of force majeure such as, war, riots, strikes, unavailability of suitable and sufficient labor, material, or capacity or technical or yield failures and any unforeseen event beyond its control, including, without limitation, any technological or physical event or condition which is not reasonably known or understood at the time of the sale of the defective Product(s) or the notification of the relevant warranty claim under this Limited Warranty.

Warranty Assignment

This Limited Warranty is only applied when the Products remain installed in their original installation location.

Validity

This Limited Warranty shall apply to Product(s) manufactured after 1st January 2014. This Limited Warranty shall be valid until a new revision is issued by Antaisolar.

No other Warranty

Unless modified in a writing signed by an officer of Antaisolar, the Limited Warranty set forth herein is the only express warranty (whether written or oral) by Antaisolar applicable to the Products and no one is authorized to restrict, expand or otherwise modify this Limited Warranty.

Miscellaneous

If any provision of this Limited Warranty is held invalid, unenforceable or contrary to law then the validity of the remaining provisions of this Limited Warranty shall remain in full force and effect.

MAINTENANCE AND CLEANING



6005-T5 anodized aluminium is largely maintenance free. Only in highly polluted or marine conditions is rinsing with clean water required, during scheduled panel cleaning.

REFERENCES

AS/NZS 1170.2:2011/Amdt 3:2012 on wind actions

AS/NZS16641.1:1997 on aluminium structures

AS1720.1:2012 on timber structures

AS/NZS4600:2005 on cold-formed steel structures

AS3566-2011, self-drilling screws for the building and construction industries.

CONTACT DETAILS:

Xiamen Antai New Energy Tech. Co., Ltd.

Address: Room 402, No.21 Wanghai Road, Software Park II Siming District, Xiamen, China 361008

Tel: +86 592 5902557

Fax: +86 592 5508270

Email: info@antaisolar.com

APPENDIXES:

- Array Frame Engineering Certificate - Flush Mount (Tile Roof)
- Array Frame Engineering Certificate - Flush Mount (Tin Roof)
- Array Frame Engineering Certificate - Flush Mount with Kliplok Clamps

These Engineering Certificates contain important installation requirements. Please obtain these certification from your distributor.

